

BALL VALVES RK-PROBALL

KH 3T S (NC), ¼" - 4", PN63/100 safety spring locking device

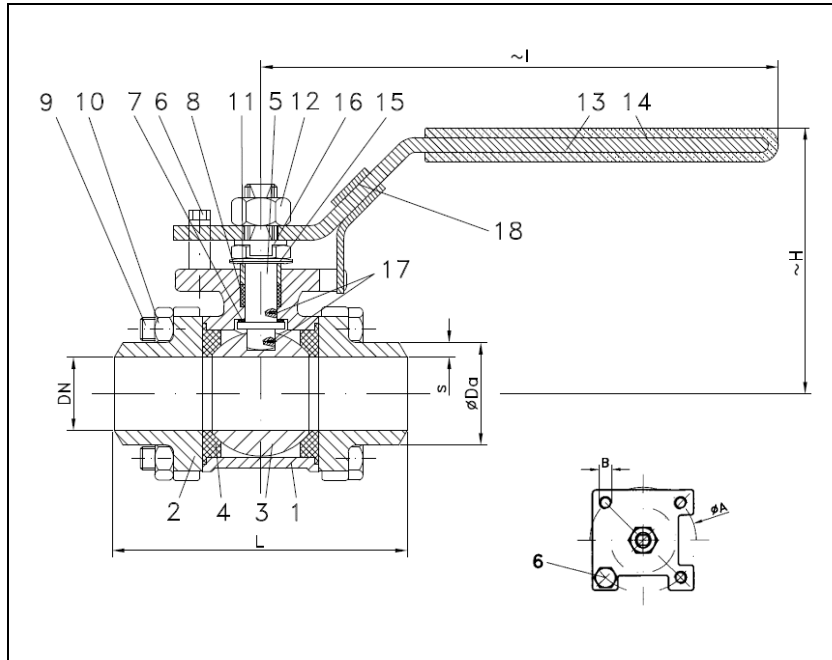

Ball valves RK-Proball KH 3T all sizes are also available with pneumatical, electrical or hydraulic actuators.

No.	Part	Material	Material
1	body	1.0619	1.4408
2	cap	1.0619	1.4408
3	ball	1.4408	
4	seat	KFG	
5	stem	1.4401	
6	stop pin	1.4301	
7	washer	KFG	
8	stem packing	KF	
9	hex. screw	A2-70	
10	hex. nut	A2-70	
11	thrust washer	1.4301	
12	hex. nut	A2-70	
13	lever	1.4301	
14	insulation cover	Vinyl	
15	plate spring	1.4310	
16	locking plate	1.4301	
17	antistatic element	1.4401	
18	spring locking device	1.4301	

Ball valve with butt weld ends
full bore

face to face acc. to DIN 3202-S13
butt weld ends acc. to EN 12627

Specification:

Three-piece ball valve, butt weld ends acc. to EN 12627, face to face dimensions acc. to DIN 3202-S13, full bore, blow-out-proof stem, body material stainless steel (1.4408) or steel (1.0619), antistatic device, free of non ferrous metals, seat KFG, stem packing KF, disc spring loaded adjustable, top flange DIN EN ISO 5211, approved by PED, certified acc. to GERMAN clean air act VDI 2440, lever with safety spring locking device.

Marking: RK-Proball
Types: KH 3T S (NC)-1.0619
KH 3T S (NC)-1.4408

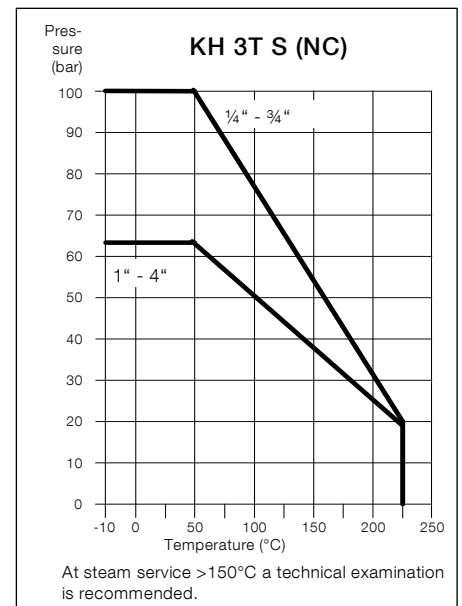

Ordering example:
KH 3T S (NC), 2", PN 63, 1.4408,
safety spring locking device

Dimensions

DN mm	DN inch	PN	dimensions (mm)				top flange ISO 5211			Kv-value	torque	weight	
			Ø Da	S	H	I	L	Ø A	B	m ³ /h	Nm	kg	
8	¼	100	13.7	2,60	63	118	70	F03	36	M5	6	3	0.5
10	¾	100	17.2	3,35	63	118	70	F03	36	M5	7	3	0.5
15	½	100	21.3	2,80	67	135	75	F04	42	M5	10	5	0.7
20	¾	100	26.9	2,95	73	135	90	F04	42	M5	25	10	0.9
25	1	63	33.7	3,45	80	168	100	F05	50	M6	35	11	1.3
32	1 ¼	63	42.4	5,20	87	168	110	F05	50	M6	46	20	1.9
38	1 ½	63	48.3	5,15	103	205	125	F05	50	M6	80	26	2.9
49	2	63	60.3	5,65	112	218	150	F07	70	M8	110	30	4.7
65	2 ½	63	76.1	5,55	156	280	190	F07	70	M8	310	70	9.7
80	3	63	88.9	4,45	163	376	220	F10	102	M10	360	90	14.6
100	4	63	114.3	7,15	194	376	270	F10	102	M10	820	120	25.8

06/2016

Subject to modification.